

HYDRDUTY

HEAVY-DUTY. LONG-LIFE. PATENTED. GUARANTEED.

WASHDOWN-DUTY MOTORS



HYDRDUTY

HYDRDWASH[™]

SERIOUSLY EQUIPPED FOR HARSH ENVIRONMENTS AND SPECIALTY APPLICATIONS

 **BLUFFTON** MOTOR
WORKS

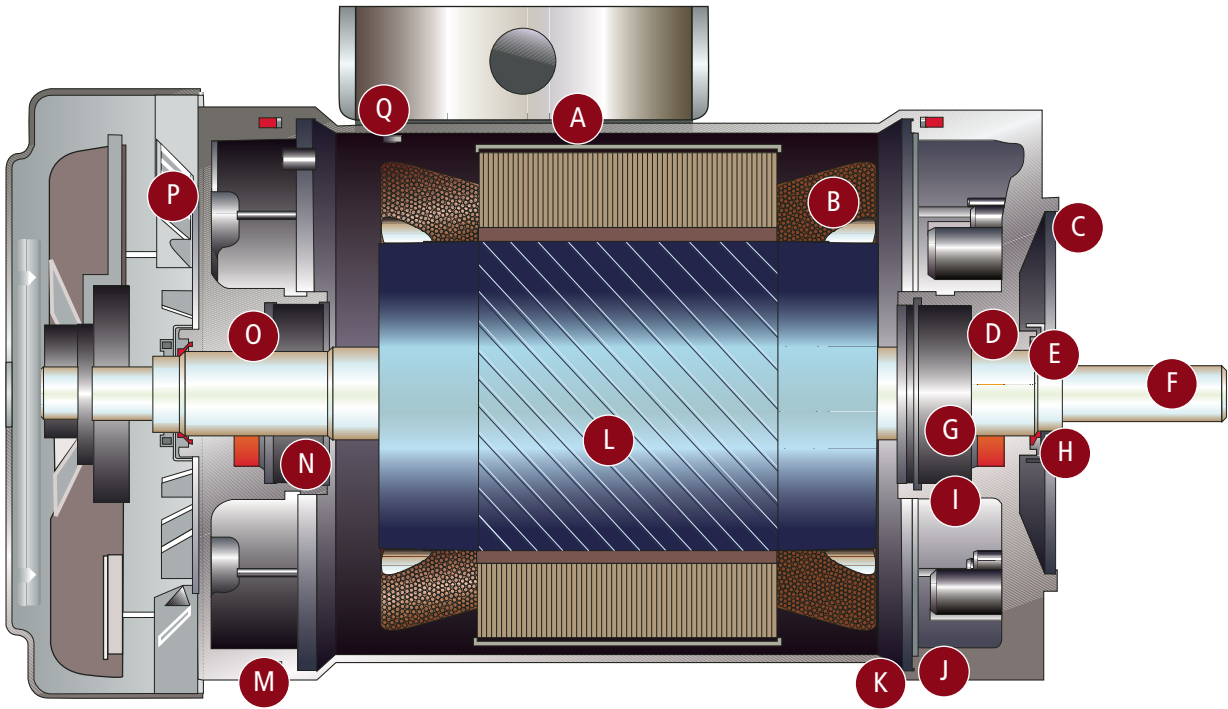

Protected Inside and Out by the Leading Submersible Motor Technology.

By successfully combining engineering disciplines, Bluffton Motor Works' revolutionary HydroDuty motors' solutions are the perfect and dependable choice of motors for operation in harsh, high moisture or specialty environments. The stainless steel HydroDuty motor, protected inside and out by the leading submersible motor technology, is designed for unequaled operation in washdown, corrosive and specialty manufacturing environments. Expect a longer motor life from HydroDuty motors even when used in applications that subject the motor to high-pressure washdown spray (i.e. food processing sanitation procedures), high levels of humidity and/or condensation, direct exposure to the outdoor elements, exposure to salt air/water, or exposure to corrosive chemical fumes/solutions. Applications where HydroDuty will excel are food processing, pharmaceutical production, corrosive chemical processing/handling, harsh manufacturing processes, marine/outdoor duty, and other extreme operating environments.

HydroDuty... Built To Outlast Them All!

Why HydroDuty?

Bluffton Motor Works HydroDuty line of washdown and specialty motors are simply the best!

Innovation of design, patented application of technology, superior materials and advanced manufacturing process make the HydroDuty the longest life-cycle washdown duty motor available on the market today.

Design Features

A	Indelible Laser-Etched Nameplate
B	SprayGuard™ Encapsulated Windings*
C	Center Cavity Drains*
D	Internal Lip Seal
E	Outside Check Seal* (both ends on TEFC)
F	Stainless Steel Shaft
G	Double-Sealed Ball Bearings
H	External Stainless Slinger (both ends on TEFC)*
I	Drip Grooves*
J	O-Ring
K	Flared Shell*
L	Epoxy-Coated Rotor
M	O-Ring
N	Double-Sealed Ball Bearings
O	Internal Lip Seal
P	Breather Vent*
Q	Potted Lead Wires*

*Exclusive Patented Features

Features and Benefits:

ALL-STAINLESS STEEL EXTERNAL COMPONENTS

- Shell
- Conduit box and cover
- Endbells
- Shaft
- External shaft slinger
- Fan canopy for ratings requiring TEFC

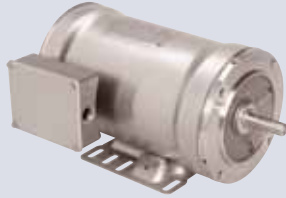

ADVANCED PROTECTION TECHNOLOGY

- Oil- and water-resistant breather vent (oleophobic and hydrophobic) *
- Extended rabbet construction for tight interference fit
- Flared shell for condensation relief *

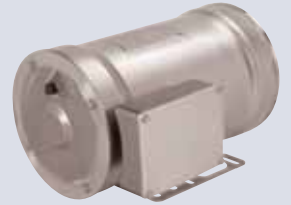

BEARING PROTECTION

- Stainless steel high-pressure external shaft slinger *
- High quality, premium seal (one-way check seal) *
- Custom internal lip seals
- Center Cavity Drains
- Double-sealed ball bearings
- Drip grooves on internal endbell hubs *
- Extended, tight fit shaft clearance hole

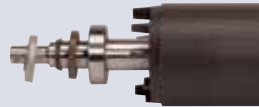

SUBMERSIBLE MOTOR TECHNOLOGY

- Moisture-managed conduit box
- Conduit lead wire entrance potted with encapsulant *
- Custom-designed cast stainless conduit box.
- Contaminant-resistant connector kit for water-tight motor lead connections *



SPRAYGUARD™ ENCAPSULATED WINDINGS

- Submersible motor technology
- Encapsulation compound with enhanced heat-transfer capability
- Potted conduit lead wire entrance *
- Fully inverter-duty capable

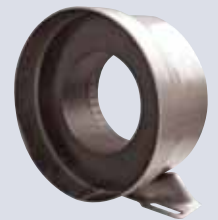

**Exclusive Patented Features*

Performance and Specifications Data

- 3 Phase, 1140, 1725 and 3450 RPM
- NEMA 56C, 145TC and 184TC
- C-face with keyed shaft
- With rigid base or no base
- UL and other agency approvals
- Stock product offering to cover popular FHP ratings



HydroWash Washdown Duty Motor

HydroWash is the perfect white painted washdown duty motor for multi-shift meat, poultry and food processing plant applications, dairy, pharmaceutical and general processing applications.

The HydroWash washdown duty motor includes many of the patented features of the HydroDuty stainless motor, including:

Features

- Potted and Welded Conduit Box – provides custom designed, secure box with moisture-management system
- Custom Bearing Protection - stainless steel high-pressure external shaft slinger, custom internal lip seals, double sealed ball bearings
- Proprietary Lead Splice Kit
- Corrosion-resistant White Epoxy paint application – withstands ASTM extreme spray tests for a long-lasting finish
- Oil and Water-resistant breather vent – utilizing oleophobic and hydrophobic technology
- Inverter-duty capability
- Stainless steel shaft
- Popular ratings – 1/2-2HP, 3450, 1750, 1140 rpm

NOTE - Custom engineered models available – Contact Bluffton Motor Works for details



HydroDuty “Picker-Plus” Feather Picker Motors

Bluffton Motors has expanded the revolutionary HydroDuty product lineup to save you time and money. Finally, a motor that you can count on in feather picking applications.

- Oversized Shaft End Bearings
 - Outstanding performance when compared to competitors' medium or light bearings
 - Rugged design to handle tough side load forces
- Top mounted conduit box
- SprayGuard encapsulated windings
 - Superior winding protection available in washdown motors
- Other patented features found on Bluffton Motor Works HydroDuty motors

The “Toughest” Washdown and Specialty Motor earned that reputation - the hard way!

HydroDuty is the preferred washdown motor for the leading U.S. poultry processing company for good reason. HydroDuty has survived for over 4 years of actual in-plant applications without fail, significantly improving plant efficiencies and providing dramatic cost savings.

The performance of HydroDuty motor systems excel in the these OEM and Production applications*:

Food Related	Other
Poultry / Meat / Seafood Processing	Pharmaceutical / Medical Device Manufacture
Dairy Processing	Marine Industry
Ice Cream Manufacture / Frozen Foods Processing	Boat Lift Manufacture
Fruit and Vegetable	Chemical Manufacture
Commercial Bakeries	Auto / Vehicle Wash Equipment
Beverage and Brewery	Recreational / Health & Fitness Equipment

* Contact your Bluffton Representative or Technical Services with any specific application design questions at 800.579.8527 or visit our website www.blmworks.com



Bluffton Motor Works, LLC (BLMW) has over 60 years experience in the successful design and manufacture of fractional horsepower electric motors. Formerly a division of the Franklin Electric Company, Inc., BLMW is now a privately held company with corporate offices and manufacturing facilities located in the heart of the Midwest in Bluffton, Indiana, USA .

BLMW specializes in the development of custom-engineered motors to meet customers' unique specifications and/or for severe duty applications. We like to take on the tough jobs, utilizing highly experienced engineering and manufacturing personnel to design the optimal motor for your application. Since our motors are built in the USA, we take care to ensure that a BLMW motor is consistently excellent in both quality and performance. We have earned our reputation for being a market leader in customer service, and we work diligently to make sure our motors are delivered when promised.

Whether the application is in a physically challenging environment, such as in severe washdown, or a tough performance issue, like repeated rapid cycling or variable frequency drive, BLMW is able to provide the solution to your extreme motor issues.

If you have an application that needs improvement in the performance and/or life of the electric motor, you should contact Bluffton Motor Works

Visit us at www.blmworks.com

1.800.579.8527

Made in USA

Testimonials

"It takes a quality product, designed to withstand the environment, which the Bluffton Motor Works HydroDuty motors have proven to be."

Plant Engineer – Storm Lake, Iowa

"In almost 20 years, this was the first washdown motor I have seen that did more than just look nice! It is engineered to last and all it takes is installing one to find out! It's by far the best motor I've seen on the market."

Vice President- Sales Division, Electrical Supply & Distributor – Cambridge, MD

"I will recommend the HydroDuty motor for anyone to use anywhere, especially in a wet, harsh environment."

Maintenance Manager – Monett, MO

"It's the only washdown motor we use."

Maintenance Manager – Dexter, MO



410 East Spring Street • Bluffton, IN 46714 U.S.A.
1.800.579.8527 • P: 260.827.2200 • F: 260.827.2396
Visit us at www.blmworks.com • Made in USA